



SMOKELESS GRILL OPERATION MANUAL – EN

SPRW-IS



Intertek
5023852

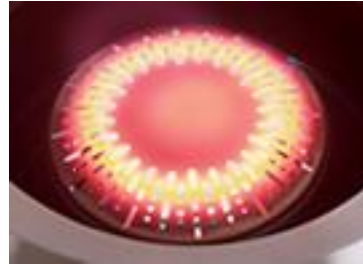
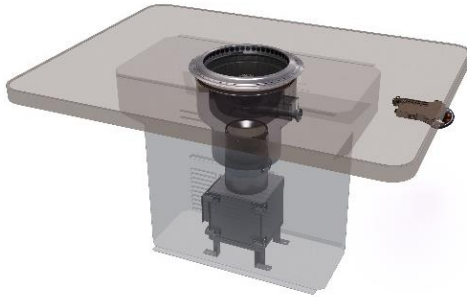

Intertek

Thank you for purchasing SHINPO Smokeless Grill.

1. Before operating this product, please read and understand the instructions contained in the manual.
2. Keep this manual in a place where it can be reached for immediate references.
3. If necessary, please contact your distributor from whom you have purchased the product or us for clarification and/or further instructions.
4. Tested in accordance with ANSI Z83.11: 2016 Ed.4 CSA 1.8: 2016 Ed.4 standard for gas food service equipment.
5. Check your local building codes for the proper method of installation. Use professional, qualified and licensed contractors and service persons to install and maintain products.
6. Installation needs to be in accordance with NFPA 96 (USA). For installation in Canada, please refer to the Authority Having Jurisdiction for requirements on installation of commercial cooking equipment.
7. Exhaust air flow rate: 260 CFM. The exhaust air flow rates were established under controlled laboratory conditions.
8. Greater exhaust air is required for complete vapor and smoke removal in specific installations.
9. Do not use any container with oil on a griddle always keep drain pan filled with clean water.
10. This product is designed for commercial use. For indoor use only.

CONTENT		
1. Parts Identification Main Unit.....	2	7. Dairy Inspections & Maintenance..... 13
2. Parts Identification & Accessories.....	3	Top Ring / Outer Casing / Inner Casing /
3. Safety Precautions/Interval.....	4	Drain Pan / Radiant Plate / Radiant Plate
4. Preparation before use.....	8	Stand / C-Box / Baffle Filter / Oil Tray
5. Operation Instructions.....	10	8. Burner Inspection/Maintenance..... 15
6. Recommended Cooking Time.....	12	9. Troubleshooting..... 17
		10. Safety Features..... 18
		11. Specifications..... 19

1. Parts Identification-Main Unit

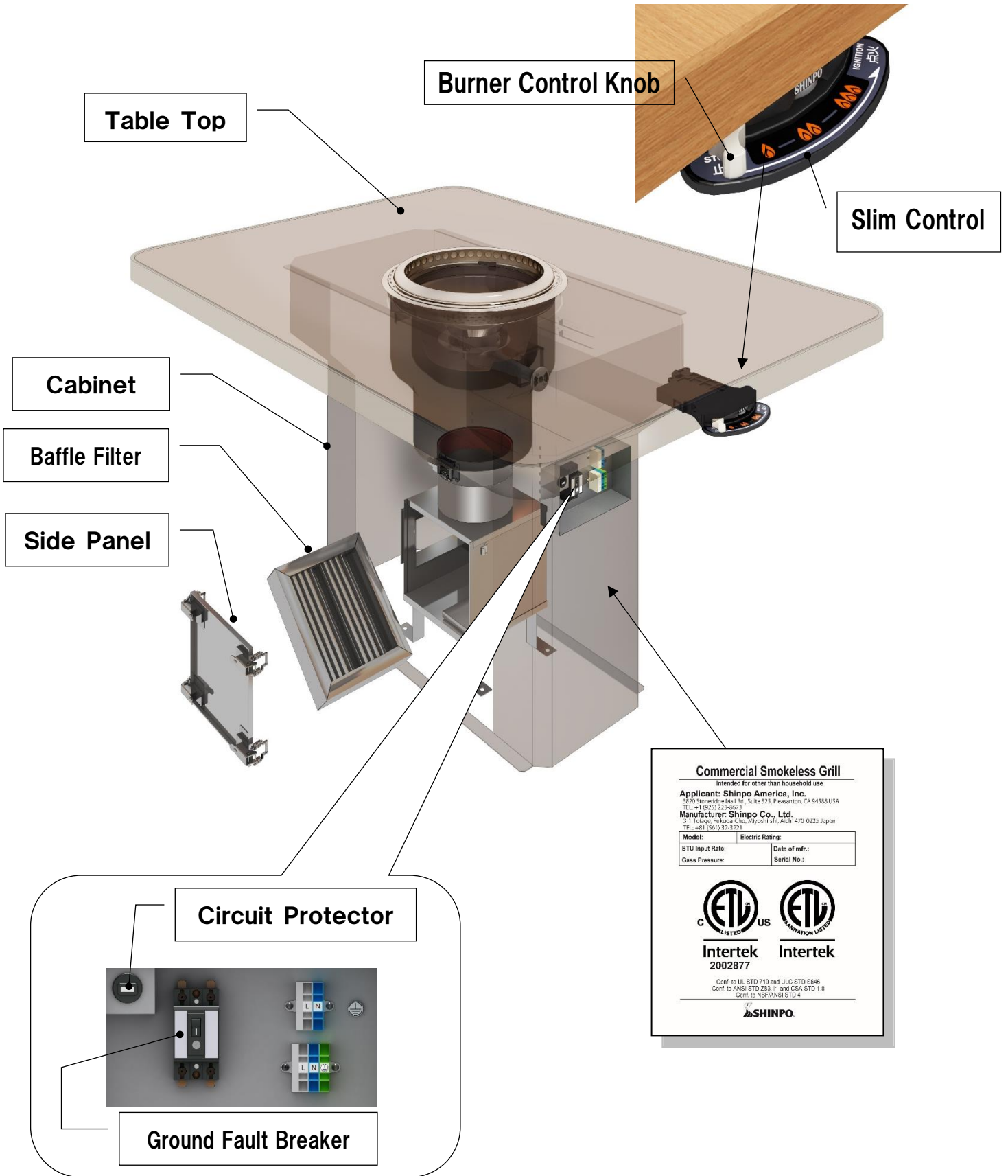

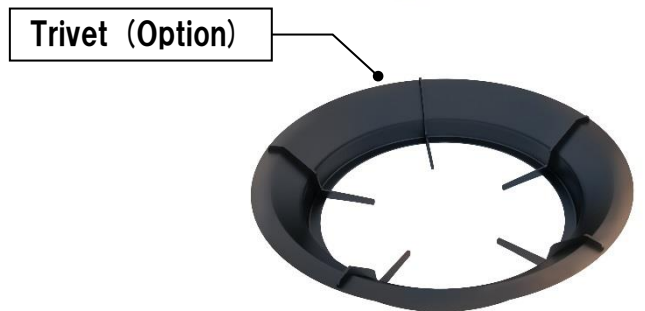
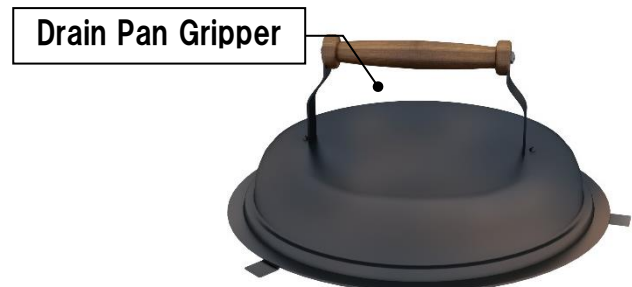
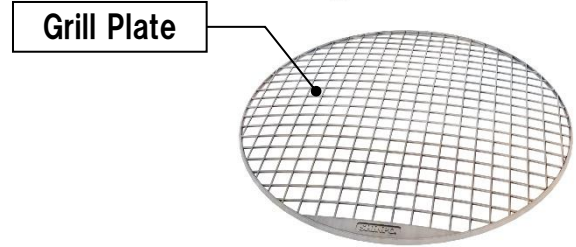
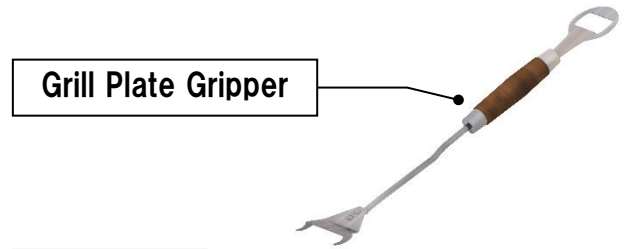
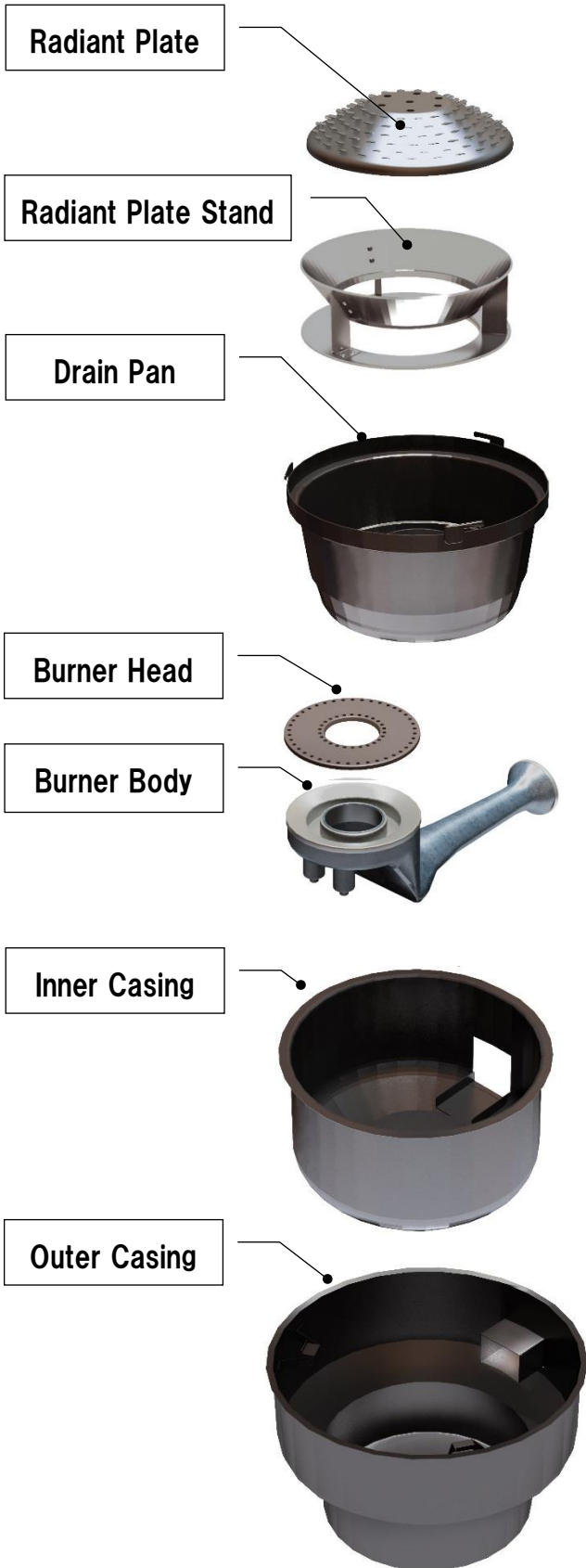

2. Parts Identification-Parts & Accessories

<The following four items are not included in SPRW-IS, may be purchased separately>
「Optional Parts」



3. Safety Precautions

We are providing these instructions with illustrations for clarity and easy understanding in order to avoid any harm to the users or damage to the properties. Insure proper installation and servicing. Have the product installed and grounded by a qualified technician. Please make sure to understand fully the meaning of each illustration before you proceed further.



	DANGER	Failure to observe this instruction may result in a situation where death or serious injury (Note 1) is imminent.
	WARNING	Failure to observe this instruction may result in a situation where death or serious injury (Note 1) may occur.
	CAUTION	Failure to observe this instruction may result in a situation where injury (Note 2) to the user or damage to the property (Note 3) may occur.

Note1: Serious injury means loss of eyesight, injury, burn (low/high temperature), electric shock, broken bone or poisoning which require hospitalization or long term outpatient treatment.

Note2: Injury means injury, burn or electric shock which does not require hospitalization of long-term outpatient treatment.

Note3: Property damage means damage to buildings, livestock or pet animals.

The illustrations denote the following precautions:

	General Caution	 Fire Prohibited	 Contact prohibited	 Disassembly Prohibited
	General Prohibition	 Must Do	 Unplug from Outlet	

◆ This product is designed for commercial use only, not for household use.

Interval

The appliances must be installed as below.

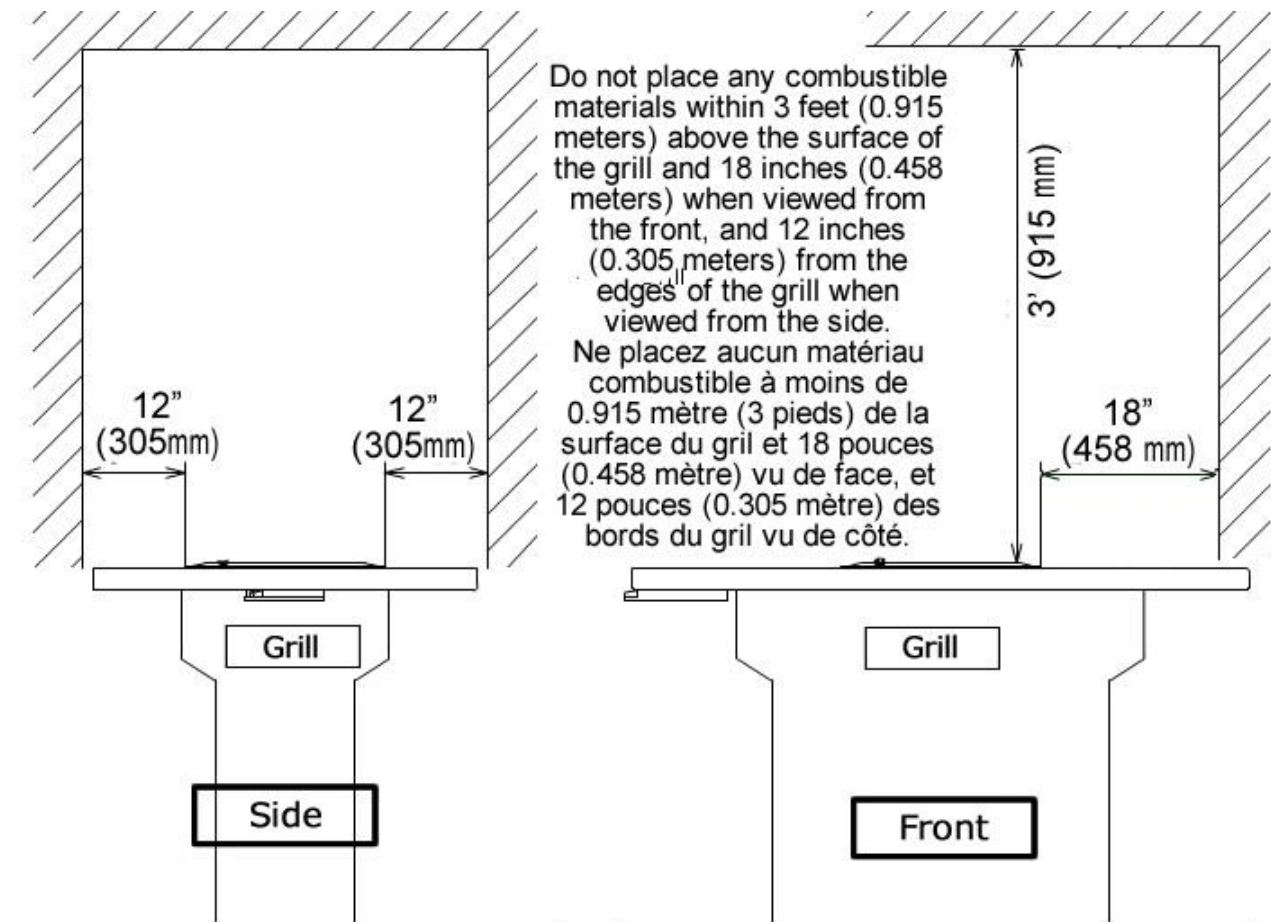

WARNING

◆ Ventilation

- ▽ Make sure to keep an exhaust fan(s) and of appropriate capacity operating while using the smokeless grill.
- ▼ Failure to observe this may cause incomplete combustion due to reduce oxygen in the surrounding area.
- ▼ It may also lower the quality of the air within your establishment.

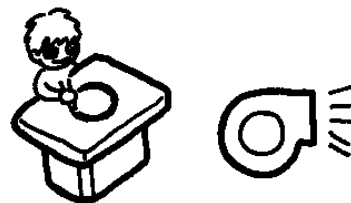

◆ Gas Supply

- ▽ Do not use other than the type of gas specified on the Rating Plate (see P.1).
If you move to a new location, check the type of gas supplied to that location.
- ▼ Failure to observe this may result in a risk of fire or explosion.
Gas Supply ⇔ Rating Plate on the Main Unit.

◆ Power Source

- ▽ Do not use other than the power source specified for this product.
- ▼ Failure to observe this may result in a risk of fire or explosion.

◆ Fire Prevention

- ▽ Do not place flammables, except food items to be cooked, near the heating surface.
- ▽ Do not use any flammable substance such as gasoline, benzine or spray.
- ▼ Failure to observe these may result in a risk of fire or burn.
- ▽ Never place any burning matter such as meat vegetable or cigarette into the smoke intake holes.
- ▽ Do not use this roaster when it is not clean.
- ▽ Do not use this roaster without an appropriate amount of water in the Drain Pan.
- ▼ Failure to observe these may result in a risk of fire.

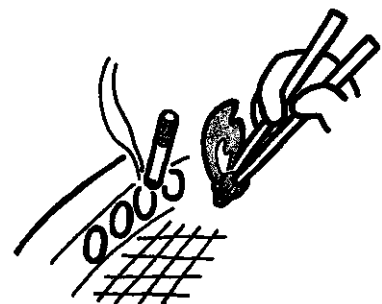

WARNING

◆ Emergencies

- ▽ If you sense an abnormal combustion, odor or sound, immediately stop the use, shut off the gas main of the unit and refer to the “Troubleshooting” section of this manual.
- ▽ In an emergency such as earthquake or fire, immediately stop the use of this product and, if it’s safe to do so, shut off the gas main of the unit. Before you use the product again, contact your distributor or us for inspection and, if necessary, repair.
- ▼ Failure to observe these may result in a risk of explosion or fire.
- ▽ In an electric storm, shut the power off at the circuit breaker or unplug the power cord.
- ▼ Lightning often causes a reverse current of electricity, which may damage the product.



◆ Proper Use

- ▽ Do not use this product for other than heating and cooking of food.
- ▼ Failure to observe this may result in a risk of accident.

▽ Do not sit, stand or place a heavy object on this roaster.

▼ Failure to observe this may result in a damage to the roaster or accident.

▽ Place or install this roaster on a level and secure surface only.

▼ Failure to observe this may result in a risk of fire or burn.

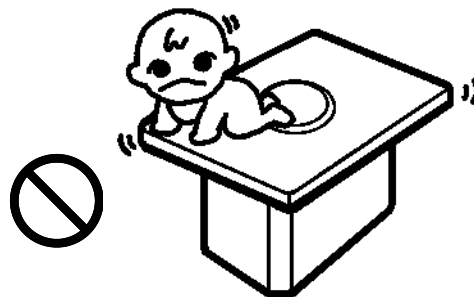

◆ Removable & Replaceable Parts

- ▽ Use only original parts or those approved by us.
- ▼ Failure to observe this may result in incomplete combustion or a damage to the product.







WARNING

◆ Disassembling

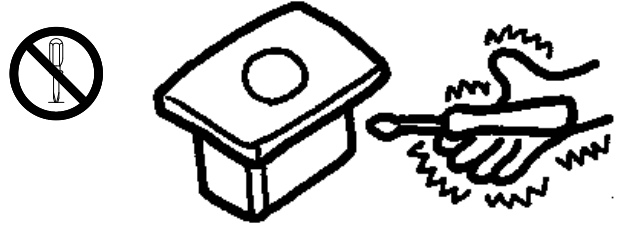
- ▽ Do not disassemble this roaster, removable parts excepted. (See P.2 for the list of removable parts)
- ▼ Failure to observe this may result in a damage to the product, electric shock or injury.



◆ Prevention of Burn

- ▽ Do not touch the heating surface or smoke holes 
- ▼ The heating surface and smoke holes get extremely hot. Touching these parts may cause a severe burn. 
- ▽ Do not touch any of the heated parts of the product immediately after use.
- ▼ Make sure that all the heated parts have cooled down to prevent a burn.
- ▽ Do not place seasoning containers or tableware near the heating surface.
- ▼ Any object placed near the heating surface may get hot enough to cause a burn.
- ▽ Do not use charcoal or food items that may crack or burst open while burning or being heated. (Make necessary preparations with food items with high water content such as squid to reduce the risk.)
- ▼ Failure to observe this may result in a risk of burn.

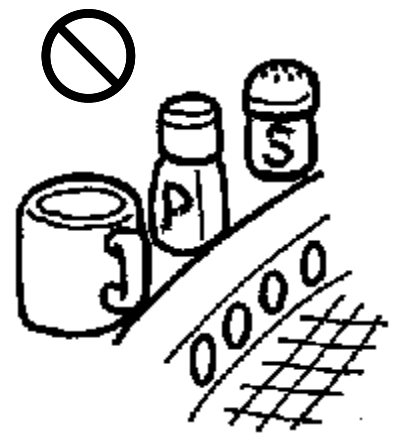
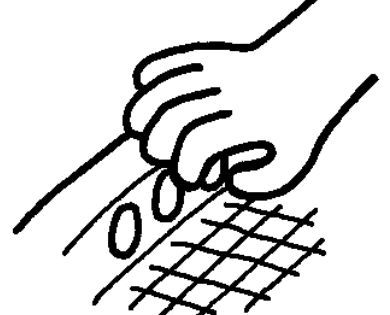

4. Preparation before use

◆Setting up parts (Refer to P.2,3)

1. Mount the Inner Casing onto the Outer Casing.

2. Mount the Burner Body onto the Inner Casing.

Note:

- ▼ Make sure that the two projections on the backside of the Burner Body go into the corresponding holes in the Inner Casing.
- ▼ Make sure that the Burner Body is sitting squarely and level on the Inner Casing.
- ▼ If the Burner is sitting off to the side or tilted, incomplete combustion may occur.

3. Mount the Burner Head onto the Burner Body.

- ▼ Rotate the Burner Head a couple of times and make sure the Burner Head is sitting squarely and level.
- ▼ If the Burner Head is sitting off to side or tilted, incomplete combustion may occur.

4. Place the Drain Pan on the bottom of the Inner Casing.

Note:

- ▼ The Drain Pan is designed to sit on the top edge of the Inner Casing.
- ▼ Clean the Drain Pan if the contact surface of the Drain Pan or Inner Casing is soiled with dust or other substances.
- ▼ If the Drain Pan is not sitting squarely, or the contact surfaces are not clean, incomplete combustion may occur.

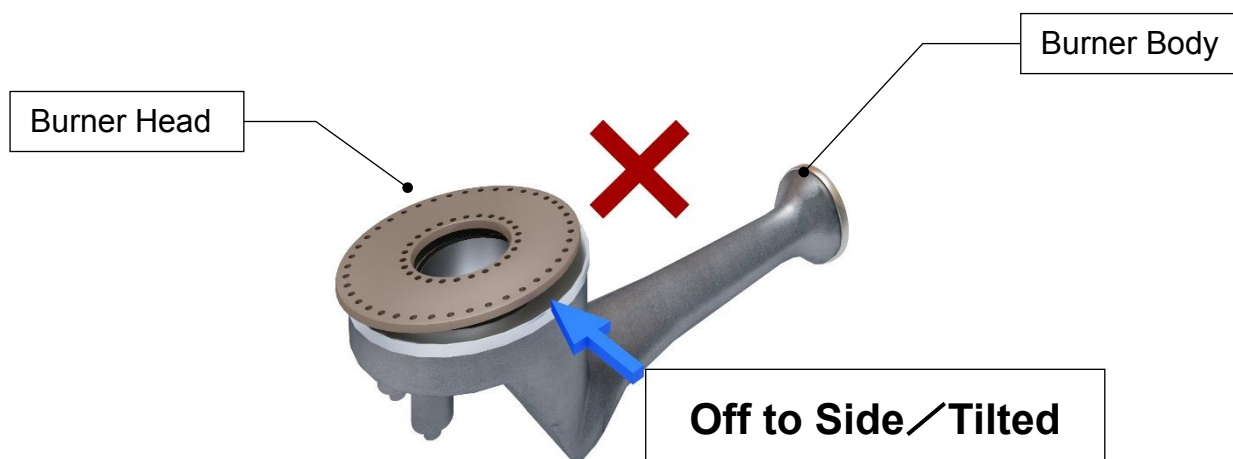

5. Pour water into the Drain Pan

- ▼ Appropriate amount is approx 1 liter.
- ▼ Do not splash water on the Burner.
- ▼ If water accidentally splashes on the holes of the Burner, remove the Burner and wipe it dry with a piece of cloth.
- ▼ If the holes are clogged with water or other substances, gas may reverse its flow at the Gas Intake of the burner and burn within the appliances.
- ▼ Make sure gas is burning before you release the knob.

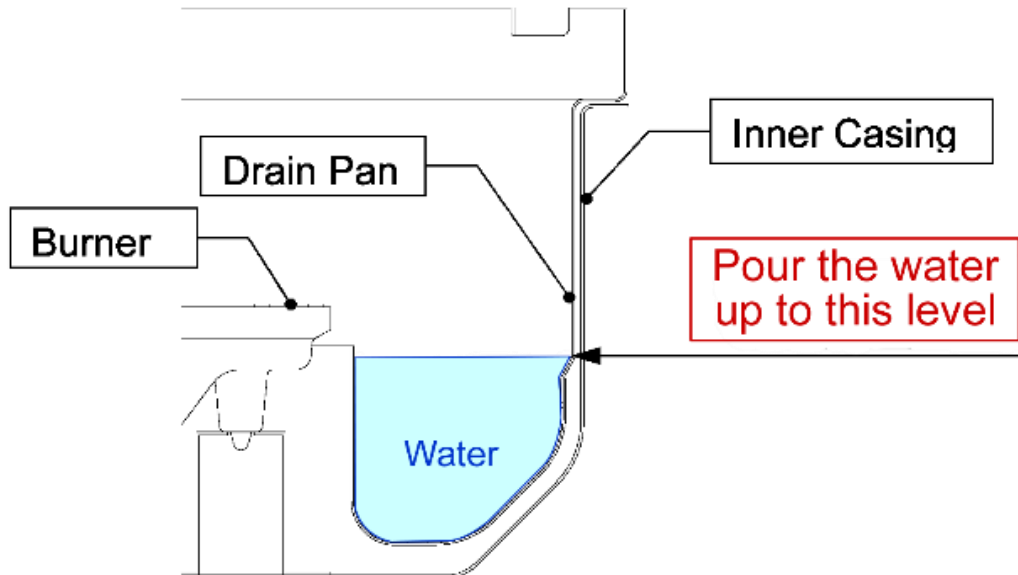

6. Place the Radiant Plate Stand on the center of the Drain Pan.
7. Mount the Radiant Plate onto the Radiant Plate Stand.
8. Mount the Top Ring onto the Drain Pan.

Note:

- ▼ The Top Ring is designed to fit inside the Drain Pan.
 - ▼ Rotate the Ring a couple of times and make sure the Top Ring is sitting squarely and level on the Drain Pan.
 - ▼ If the Top Ring is not sitting squarely or tilted, smoke from cooking may not be discharged properly or food may not be cooked evenly.
9. Place the Grill Plate using Grill Plate Gripper.
 - ▼ Use Grill Plate approved by us.
 10. Check the following again before use.
 - ▼ All the parts are installed correctly.
 - ▼ Drain Pan holds an appropriate amount of water.

★ Pot Cooking

- ▼ Remove the Top Ring and mount the Trivet(Sold separately) on the Drain Pan.
- ▼ Use Trivet approved by us.

5. Operation Instructions (Slim Control Type)

Before you turn on the power and open the Gas Shutoff, make sure the Burner Control Knob is at Off position and that every direction in the “Preparation before use” section of this manual has been precisely followed. Also make sure that the Exhaust Fan is operating normally.

◆ Ignition

- | | |
|---|--|
| <p>① Slowly slide the Burner Control Knob all the way to Ignition position.</p> <ul style="list-style-type: none"> ▼ When you try to ignite for the first time, you may have some difficulty due to the air remaining in the gas pipe. ▼ Remove the air completely and try again. | <p>② The Igniter makes a clicking sound and ignites gas. Make sure gas is burning before you release the knob.</p> <ul style="list-style-type: none"> ▼ If the Burner fails to ignite, slide the Knob back to Off position. ▼ Wait for a while and try again. ▼ Make sure you wait long enough to disperse the gas within the appliance to avoid an explosive ignition. |
|---|--|

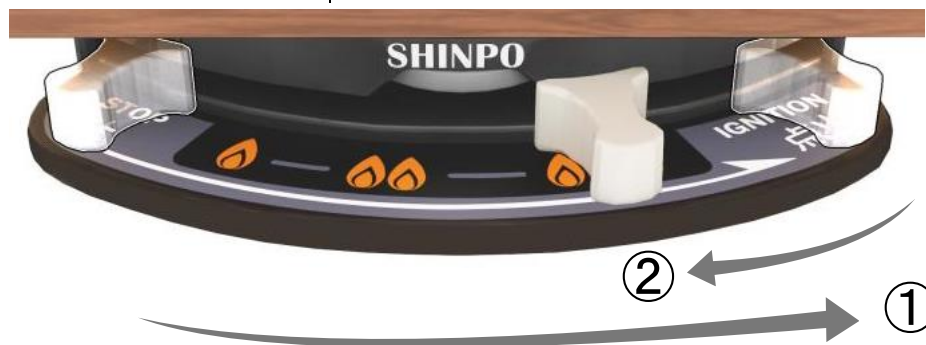

◆ Adjusting flame force

The flame strength can be adjusted in 3-step of High, Medium and Low by controlling the knob.

① HIGH→MEDIUM

- ▼ Slowly shift the knob in left (in direction of STOP), and it will stop at position of MEDIUM making a clicking sound.

② MEDIUM→LOW

- ▼ Further shift the knob in left slowly, and it will stop at position of LOW making a clicking sound.



①② LOW/MEDIUM→HIGH

- ▼ Slowly slide the Burner Control Knob all the way to IGNITION position.
- ▼ Release your hands, and it will stop at position of HIGH.

①②③ LOW→MEDIUM

- ▼ Slowly slide the Burner Control Knob all the way to IGNITION position.
- ▼ Shift the Knob in left, and it will stop at position of HIGH and MEDIUM making a clicking sound.

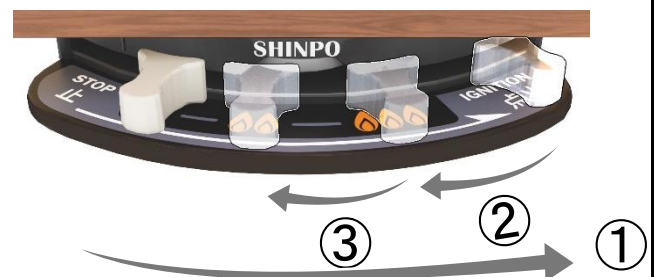

◆ Extinguishing Fire

- ① Slowly slide the Burner Control Knob to OFF position to turn off the burner.













- ② Make sure the Burner Control Knob is at OFF position

- ③ Make sure the Burner is off. Close the Gas Shutoff Cock and turn off the power.
▼ Allow the appliance to cool down before you touch it.

- ④ Make sure the appliance has cooled down to a safe level. Clean the appliance following the directions in the “Daily Maintenance” section of this manual.

6. Recommended Cooking Times

- (1) The Shinpo SPRW-IS Smokeless Grill was developed for optimum use based on the suggested cooking times, below. By recommending that your customers follow these suggested cooking times, the quality of the food they grill will be enhanced and the grill's smoke-removing exhaust system will operate at peak performance.
- (2) Cooking time will vary due to the thickness of meat and the heat of the grill. Please inform customers to consume what they have cooked immediately and not to leave items on the grill.
- (3) Note: The cooking times are a rough estimate of the number of seconds it takes to cook for one side. The cooking time for both sides is doubled.

				
Beef Toro 50~90 sec.	Sirloin Flap 50~90 sec	NY Steak 60~120 sec	Beef Tongue 50~90 sec	Beef Prime Hanger 60~90 sec
				
Pork Belly 50~70 sec	Prime Top Sirloin 60~120 sec	Beef Filet Mignon 60~120 sec	Chicken Breast 60~90 sec	Pork 50~70 sec

Non-recommended item

- (1) Please do not use this grill to cook hamburgers or other types of beef patties. Due to the dispersed fat content of hamburger, the heat from the grill will release the fat too quickly, or the burger may crumble and fall through to the cooking element, both causing flare-ups as a result. In this case, the resulting smoke will exceed the capacity of the exhaust system, and smoke will enter the ambient environment.



Beef Patty / Hamburger

7. Daily Inspections & Maintenance

- ▼ For safe operation of this product, make sure to carry out daily inspections and maintenance.
- ▼ Make sure to close the Gas Shutoff Cock , turn off the power, check the Exhaust Fan is not operating and allow the appliance to cool down before you attempt any inspections or maintenance work.

◆Inspections

- ① Is every part or component clean?
- ② Is any part or component damaged or marred?
- ③ Is any part or component rusted or corroded?
- ④ Is every part or component present?
- ⑤ Is every part of the Grill in order?

◆Maintenance

- ① Make sure to clean the Burner and Burner Head at the start of the business. (See page 8•9•15•16)
 - ▼ Brush burnt grease and food stuff off the Burner and Burner Head.
 - ▼ When wet, make sure let them dry well or wipe dry with a piece of cloth.
 - ▼ Clogged Burner Holes may cause gas to flow backward and leak out from the Gas Intake, which may result in a risk of dangerous combustion.
- ② Clean the Top Ring after use with a piece of cloth. Make sure to clean the back side too.



- ③ Clean the Outer Casing at the close of business.
- ④ Clean the Inner Casing, Drain Pan at the close of business.
- ⑤ Clean the Radiant plate, Radiant Plate Stand at the close of business.

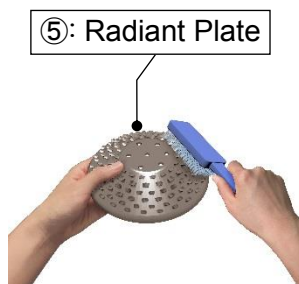

◆C-Box and Baffle Filter Cleaning

(1) The C-Box should be wiped with dry close in every week.



(2) The Baffle filter and the tray in C-Box should be washed with soap and warm water in every week.





8. Burner Inspection

Install the Burner correctly and check the burner flames by comparing to the drawings below. If necessary, adjust the Damper attached to the Gas Intake of the Burner.

※Be extremely careful not to burn yourself or your clothes. Make sure the Burner and other parts have cooled down to a safe level before you touch them.

◆ Burner Condition

Too Much Air Loud Hissing	Normal	Too Little Air Incomplete Burning
		
Close Damper	/	Open Damper

◆ Burner Air Adjustment

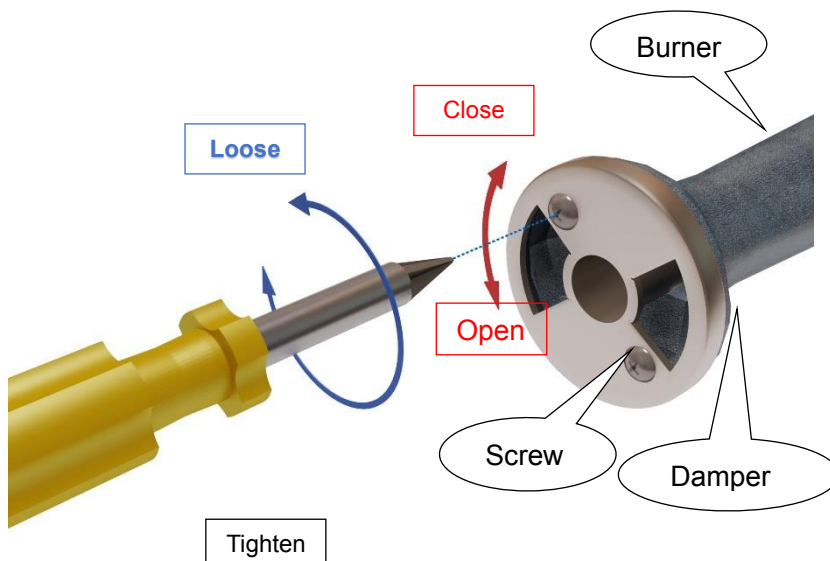

Loosen the Screw and open/close the Damper one touch at a time.

Burner Maintenance

Clogged Burner Holes (with water, grease, ashes) often causes the Burner to rust shortening the operational life span of the Burner. It also causes gas to flow backward, which may result in a risk of fire or explosions.

①

Brush the Burner Holes.
Brush thoroughly heavily
clogged holes.

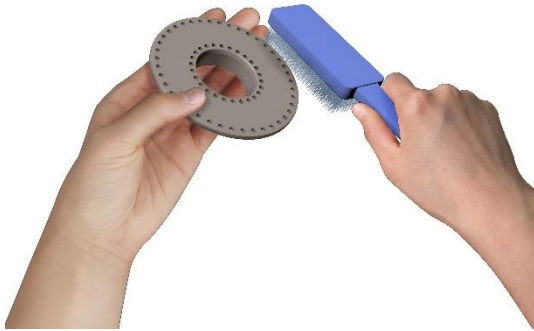
**②**

Tap a few times



Tap the Burner Head a few times with a plastic or wooden hammer to remove the rust and ashes.

9. Troubleshooting

Cause		Trouble							Solution	Reference page	
		Does not ignite	Fire goes out when the Knob is released.	Pilot fire does not ignite.	Burner does not ignite	Explosive ignition	Unstable Flames	Fire goes out while in operation			Smoke is released in the air
Gas Shutoff Cock is closed		<input type="radio"/>			<input type="radio"/>		<input type="radio"/>	<input type="radio"/>		Position the Burner Control Knob to Off. Open the Gas Shutoff Cock.	10
Air is present in the gas pipe		<input type="radio"/>			<input type="radio"/>	<input type="radio"/>				Follow the directions described in this manual.	10
Improper gas pressure	Low	<input type="radio"/>			<input type="radio"/>		<input type="radio"/>	<input type="radio"/>		Ask for professional servicing.	—
	High	<input type="radio"/>			<input type="radio"/>	<input type="radio"/>	<input type="radio"/>	<input type="radio"/>			
No electric Power		<input type="radio"/>								Check the Circuit Breaker. Ask for professional servicing.	—
Power Switch is not turned ON.		<input type="radio"/>								Turn the Power Switch ON.	—
Burner Holes are clogged					<input type="radio"/>	<input type="radio"/>	<input type="radio"/>	<input type="radio"/>		Follow the directions described in this manual.	13 16
Burner is not properly installed					<input type="radio"/>	<input type="radio"/>	<input type="radio"/>	<input type="radio"/>		Follow the directions described in this manual.	8
Malfunction of Safety Device or Ignition Device		<input type="radio"/>	<input type="radio"/>					<input type="radio"/>		Ask for professional servicing.	—
Exhaust Air is not properly discharged.								<input type="radio"/>		Contact the original contractor.	—
Parts are soiled.							<input type="radio"/>	<input type="radio"/>		Clean soiled parts.	13
Safety Device is activated		<input type="radio"/>	<input type="radio"/>					<input type="radio"/>		Follow the directions described in this manual.	18
Malfunction of Gas Control Knob.				<input type="radio"/>						Ask for professional servicing.	—
Filter Set is soiled.								<input type="radio"/>		Clean the Filter Set.	14

If the directions above do not solve your problem(s), please contact your distributor or our Service Center. Do not attempt to disassemble or repair the roaster unless you are properly trained and licensed to do so. Disassembling or repairing by untrained individual may result in a risk of appliances malfunction, injury or electric shock.

10. Safety Features

▽ Misfiring Detector

Prevents gas being discharged when the burner is not lit.

- ▼ When fire goes out for any reasons, this device detects it and shuts off the supply of gas to the Burner, preventing gas being discharged into the air.

▽ Overheating Detector

When the appliance overheats, this device shuts off the supply of gas and Sounds an alarm.

- ▼ Possible causes for overheating include:

1. Water is not present in the Drain Pan.
 2. Parts are soiled with grease and burner flames are being sucked into the exhaust duct.
 3. Exhaust Fan is not operating properly.
 4. The exhaust air volume is low due to filter clogging, etc.
 5. Clogged Burner Holes force gas to flow backward and burn at the Gas intake.
- ▼ You may resume the operation of the appliance after it has cooled down (5 to 10 minutes) and the alarm sound has stopped. The alarm will stop automatically when the appliance cools down.

※Allow the appliance to cool down before you attempt to service the appliance.

Shutting Alarm Off

You may stop the alarm manually by turning off the Alarm Switch located next to the Burner Control Knob. The supply of gas however, will not be resumed until the appliance cools down to an acceptable level.

Make sure to turn the Alarm Switch on again when normal operating conditions are restored (all the causes for overheating have been removed and the appliance has cooled down to an acceptable level).

The Alarm Switch should be turned on during normal operation. If it is turned off, warning beep will not sound and undetected overheating may result in a risk of fire.

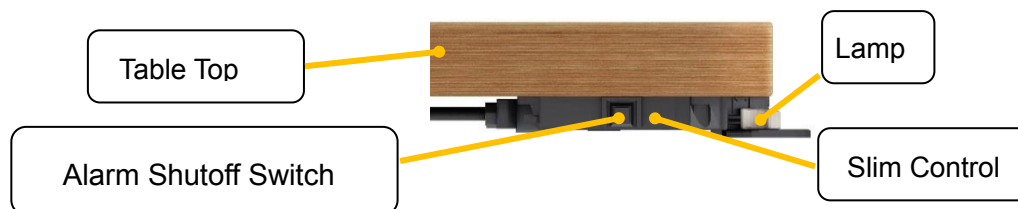

Make sure the appliance has cooled down to a safe level when you inspect the appliances.

11. Specifications

Model	SPRW-IS Radiant Plate Grill
Product	
Gas Consumption	Natural Gas: 11115 Btu/hr
Gas Connection	R1/2 Screw Connection
Power Consumption	25W
Power Source	120V
Ignition Method	Spark Discharge Ignition
Safety Feature	Overheating Detector/Misfiring Detector

Articles of consumption

Parts	Material	Endurance
Radiant plate	SUS	1 year
Radiant Plate Stand	SUS	1 year
Burner Head	SUS	3 years
Burner Body	Steel	1 year

The above endurance period is a standard for reference.

The endurance period changes by the user's use direction, use frequency, cleaning direction, and cleaning frequency.



Shinpo Co., Ltd.

Smokeless Grill, Corp. (California, USA)

5820 Stoneridge Mall Rd., Suite 325, Pleasanton, CA 94588, USA
TEL: +1 925-223-8673 FAX: +1 925-399-6568

Shinpo Co., Ltd. (Nagoya, Japan)

3-10 Yawatayama, Miyoshi-cho, Miyoshi-city, Aichi 470-0214 JAPAN
TEL: +81 561-32-3221 FAX: +81 561-32-3177

The printed installation guide can be downloaded:
<http://www.shinpo-en.com/Instruction.html>